

FICHE D'HOMOLOGATION HOMOLOGATION FORM



COMMISSION INTERNATIONALE DE KARTING – FIA



CARBURATEUR / CARBURETTOR

Constructeur	<i>Manufacturer</i>	IBEA CARBURETTOR (CH)
Marque	<i>Make</i>	IBEA
Modèle	<i>Model</i>	F4
Catégorie	<i>Category</i>	OK
Durée de l'homologation	<i>Validity of the homologation</i>	9 ans / 9 years
Nombre de pages	<i>Number of pages</i>	4

La présente Fiche d'Homologation reproduit descriptions, illustrations et dimensions du carburateur au moment de l'homologation CIK-FIA. Le Constructeur a la possibilité de les modifier seulement dans les limites fixées par le règlement CIK-FIA en vigueur.

This Homologation Form reproduces descriptions, illustrations and dimensions of the carburettor at the moment of the CIK-FIA homologation. The Manufacturer may modify them, but only within the limits fixed by the CIK-FIA regulations in force.

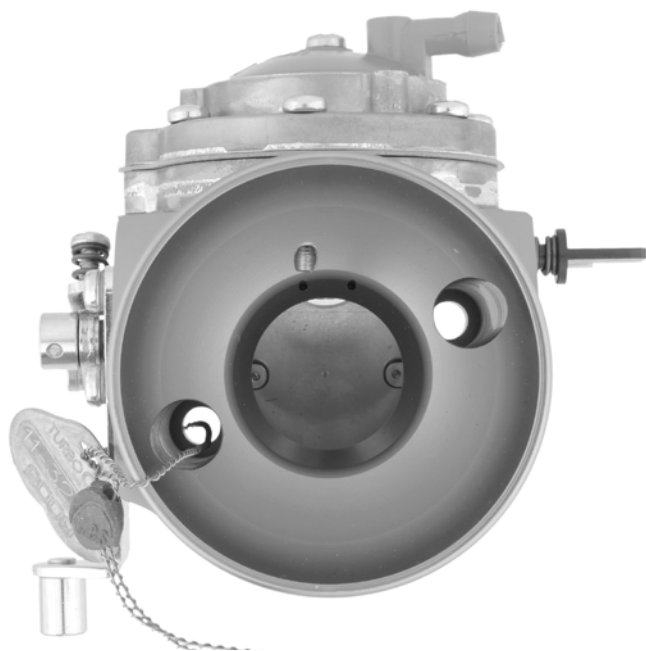

PHOTO CÔTÉ ASPIRATION
PHOTO OF INLET SIDE



PHOTO CÔTÉ RÉGLAGE
PHOTO OF ADJUSTING SIDE

Signature et tampon de l'ASN
Signature and stamp of the ASN

Signature et tampon de la CIK-FIA
Signature and stamp of the CIK-FIA

Auto Sport Schweiz GmbH
Auto Sport Suisse Sàrl
Könizstrasse 161
CH-3097 Liebefeld



PHOTO VUE ARRIERE
PHOTO VIEW FROM BEHIND

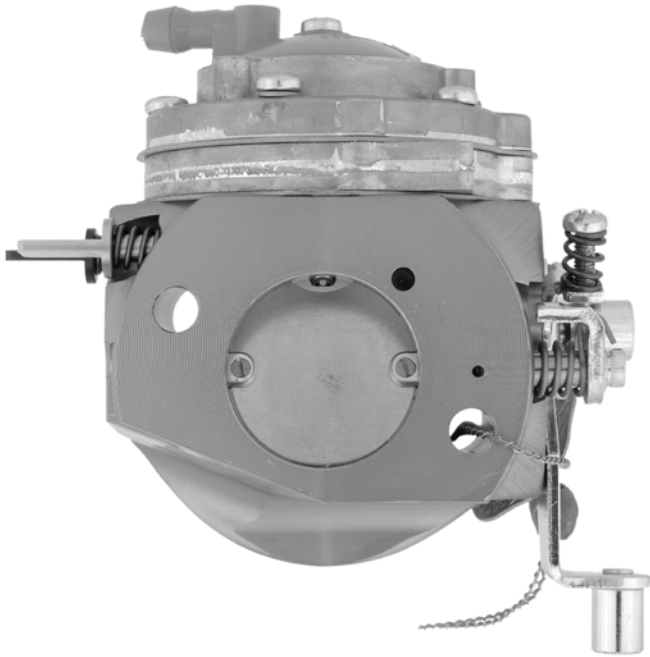

PHOTO CÔTÉ OPPOSÉ RÉGLAGE
PHOTO OPPOSITE TO ADJUSTING SIDE



PHOTO VUE DE DESSUS
PHOTO VIEW FROM ABOVE



PHOTO VUE DE DESSOUS
PHOTO VIEW FROM UNDERNEATH



PHOTO VUE DE DESSUS
PHOTO VIEW FROM ABOVE (body)

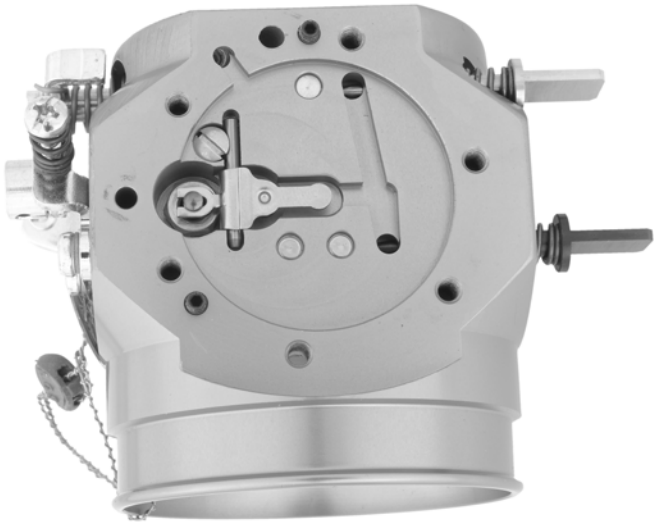

PHOTO CÔTÉ ASPIRATION (vue additionnelle)
PHOTO OF INLET SIDE (additional view)



PHOTO CÔTÉ ASPIRATION (vue additionnelle)
PHOTO OF INLET SIDE (additional view)

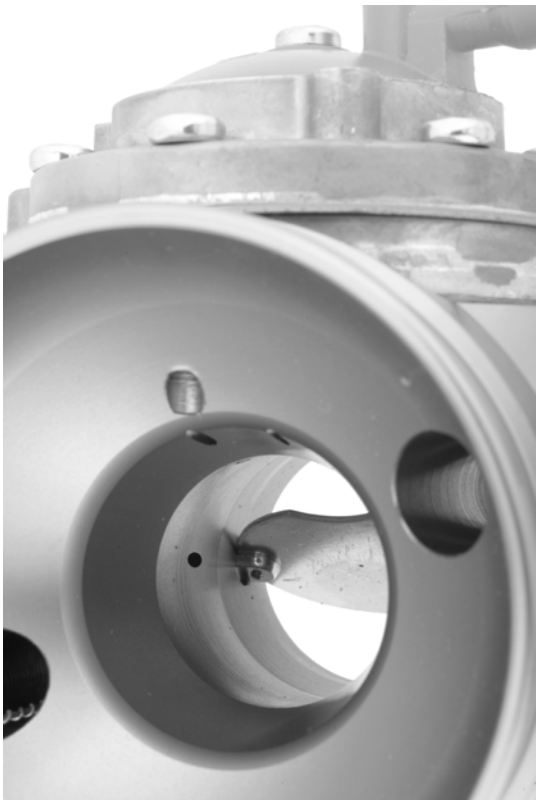
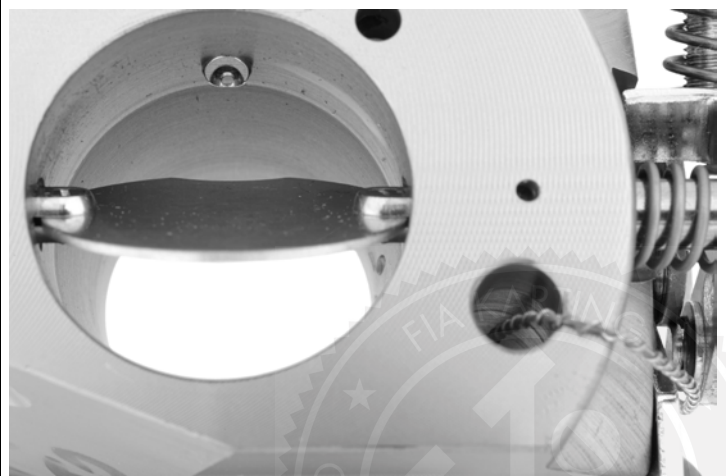

PHOTO CÔTÉ ASPIRATION (vue additionnelle)
PHOTO OF INLET SIDE (additional view)



VUE EN SECTION
CONDUIT D'ASPIRATION
INLET PORT SECTION VIEW

VUE DE FACE
CÔTÉ ASPIRATION
INLET SIDE FRONT VIEW

Echelle 1:1 / 1:1 Scale

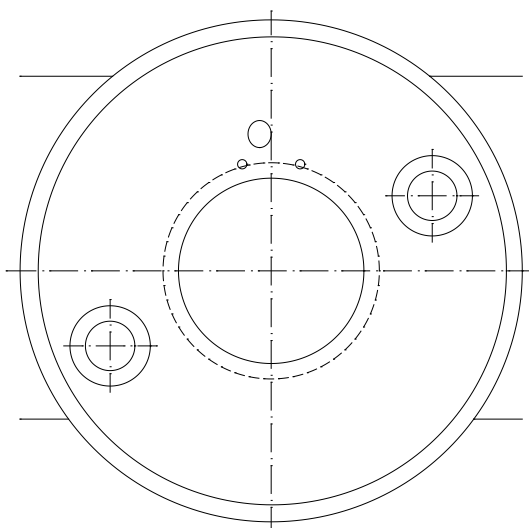
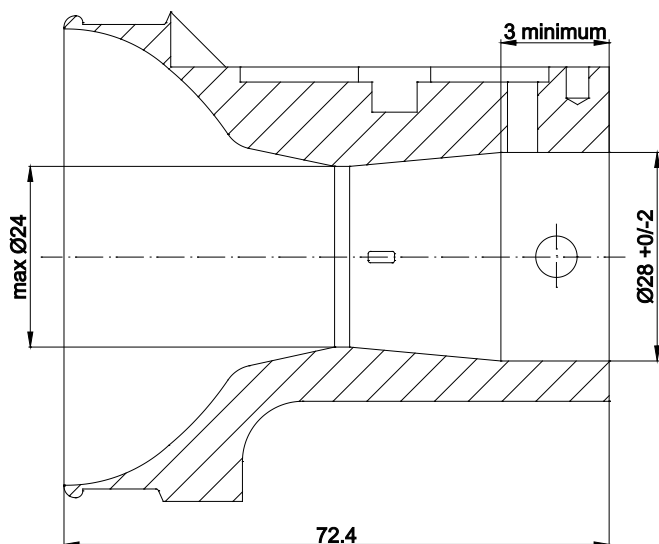

DESCRIPTION DU CARBURATEUR ET
ESQUISSE DES PIÈCES

CARBURETTOR DESCRIPTION AND
SKETCH OF PARTS

